

REVISIONS			
REV.	DESCRIPTION	DATE	APPROVED
A	Initial Release	6-16-14	NRD
B	Added Mesh Lower Tier, Divider, Side Tabs	10-13-14	NRD

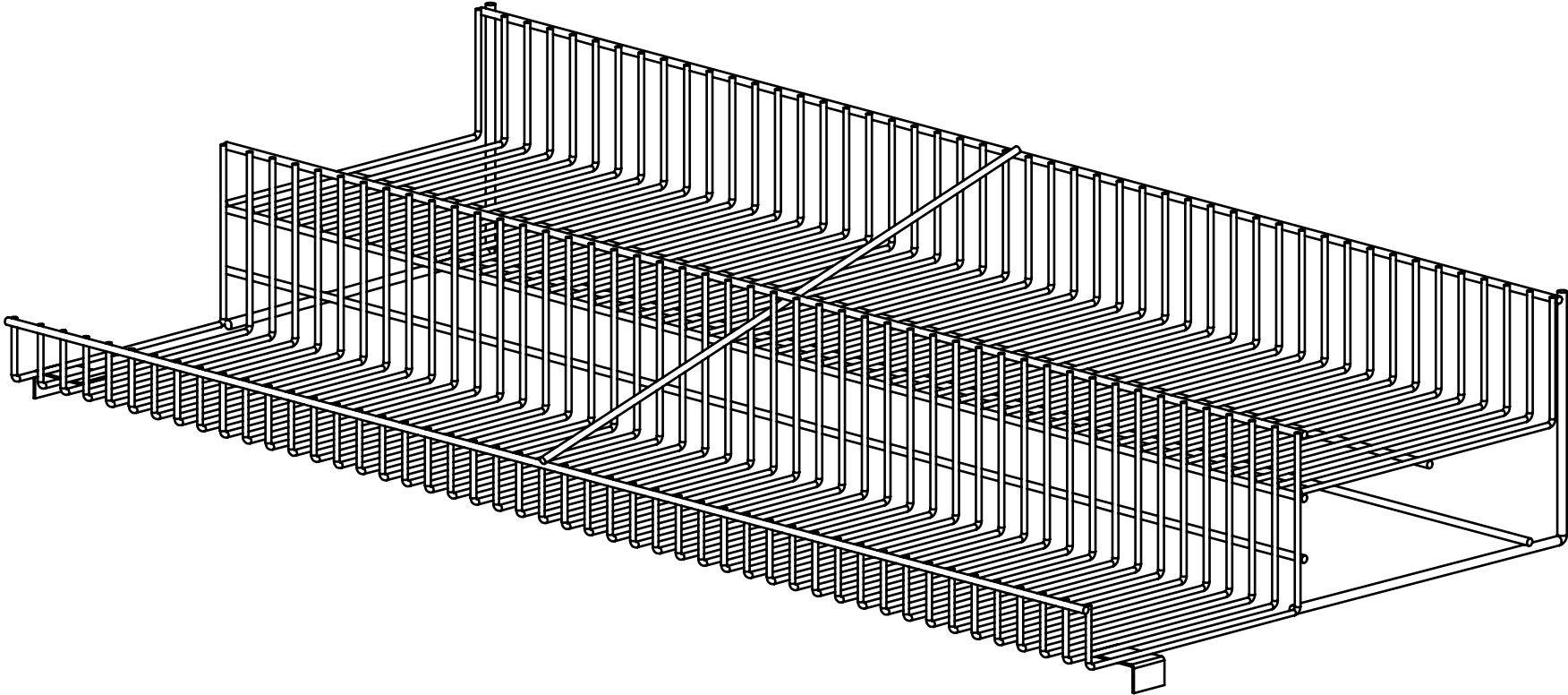

UNLESS OTHERWISE SPECIFIED  
DIMENSIONS ARE IN INCHES  
TOLERANCES ARE:  
FRACTIONS DECIMALS ANGLES  
+/- 1/32" +/- .01 +/- 1°

CUSTOMER: Circle-K

APPROVALS  
engineered  
NRD  
Drawn  
NRD  
Checked

DATE  
10-13-14  
10-13-14

<b>CDW</b> CREATIVE DISPLAY WORKS INC.	
Pastry Riser - 3ft Lower Shelf (2 Tier)	
SIZE: DWG. NO. <b>A</b>	REV. <b>B</b>
3FT	
DO NOT SCALE DRAWING	
SHEET 1 OF 5	

REVISIONS			
REV.	DESCRIPTION	DATE	APPROVED

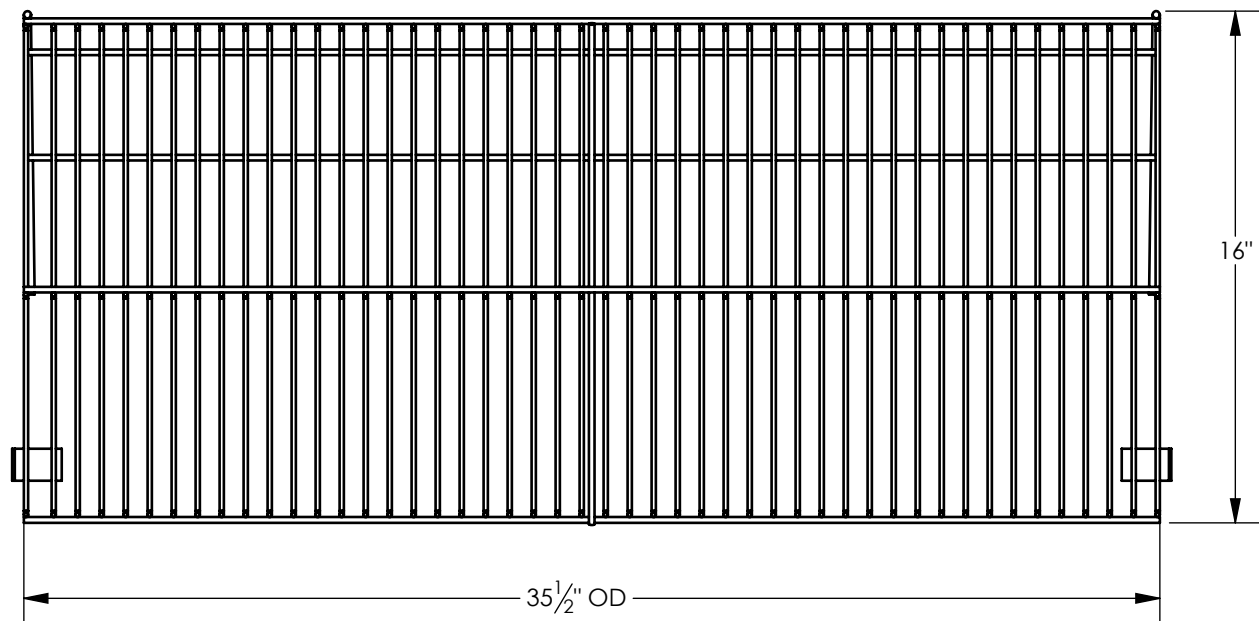

☉ 3/4" MESH

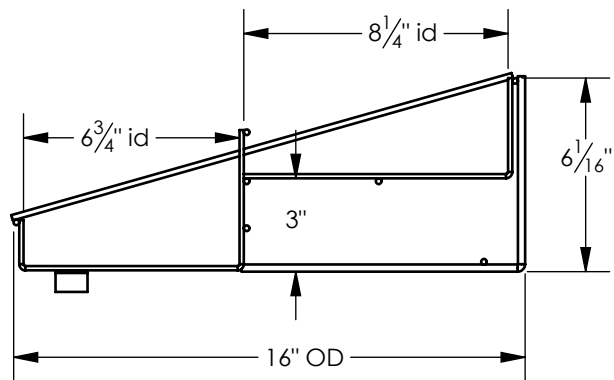
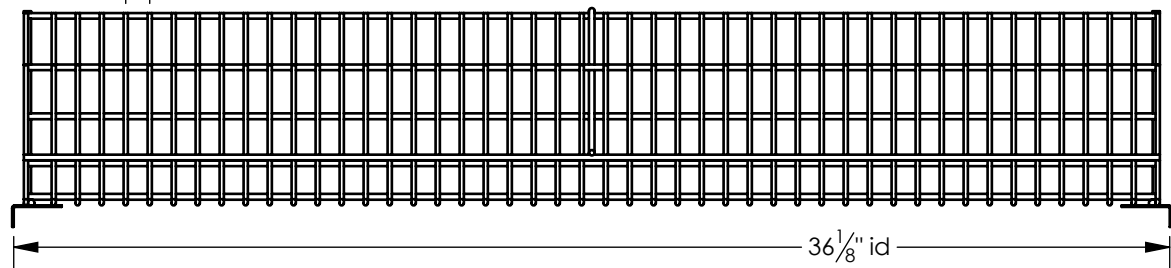

NOTES:

1. MATERIAL: 7Ga & 10Ga Wire, 4Ga Frame
2. BLANK SIZE: MISSING
3. PROGRAM: MISSING
4. BEND RADIUS: MISSING
5. BEND DEDUCTION: MISSING
6. DEBURR ALL SHARP EDGES AND NIBBLE MARKS.
7. FINISH: MISSING

UNLESS OTHERWISE SPECIFIED  
DIMENSIONS ARE IN INCHES  
TOLERANCES ARE:  
FRACTIONS DECIMALS ANGLES  
+/- 1/32" +/- .01 +/- 1°

APPROVALS	DATE
Engineered NRD	10-13-14
Drawn NRD	10-13-14
Checked	

**CDW** CREATIVE DISPLAY WORKS INC.

Pastry Riser - 3ft Lower Shelf (2 Tier)

SEE DWGS. IN  
CDW-PASTRY-RISER-LOWER-SHELF-2T-3FT

CUSTOMER: Cirlice-K

REV. B

DO NOT SCALE DRAWING

SHEET 2 OF 5

REVISIONS			
REV.	DESCRIPTION	DATE	APPROVED

10Ga Mesh  
Qty - 5

7GA Cross  
Qty - 48

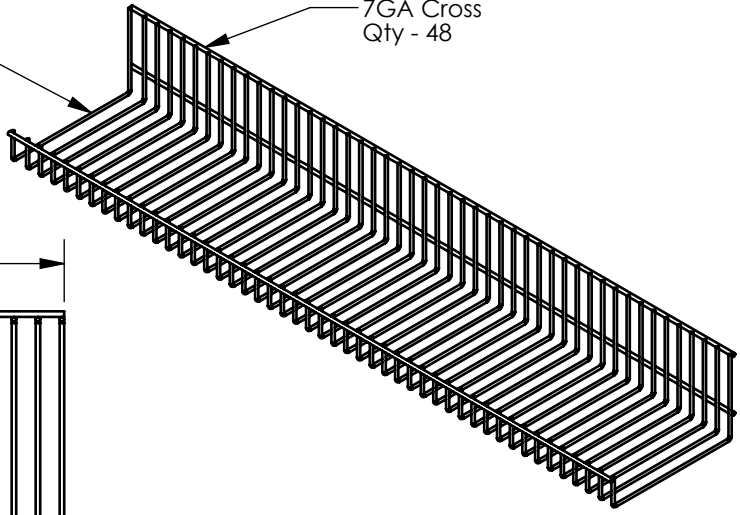
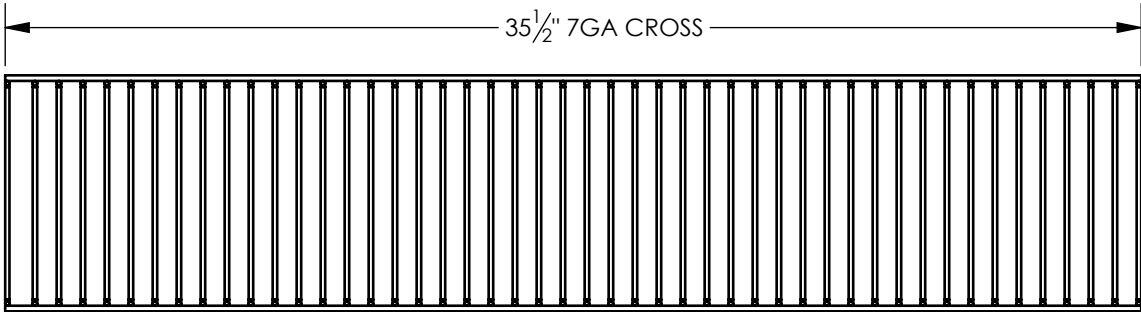

→ | ←  $\phi$  3/4" Mesh

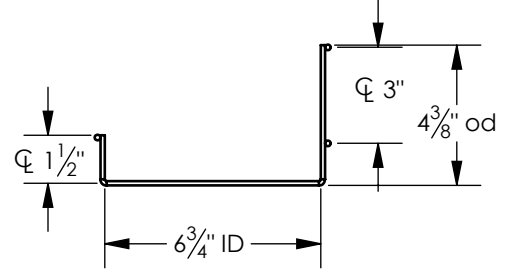
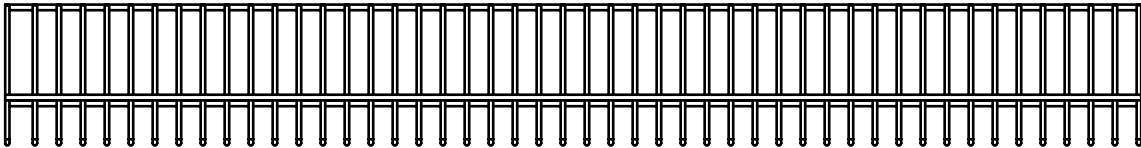

NOTES:

1. MATERIAL: 10GA MESH, 7GA CROSS
2. BLANK SIZE:
3. PROGRAM:
4. BEND RADIUS:
5. BEND DEDUCTION:
6. DEBURR ALL SHARP EDGES AND NIBBLE MARKS.
7. FINISH:

UNLESS OTHERWISE SPECIFIED DIMENSIONS ARE IN INCHES TOLERANCES ARE: FRACTIONS DECIMALS ANGLES +/- 1/32" +/- .01 +/- 1°	APPROVALS	DATE
	Engineered NRD	6-16-14
	Drawn NRD	6-16-14
CUSTOMER CRICLE-K	Checked	

**CDW** CREATIVE DISPLAY WORKS INC.

Tire #1

SIZE A	DWG. NO. CDW-PASTRY-TISER-2T-T1-ASM	REV. A
-----------	--	-----------

DO NOT SCALE DRAWING

SHEET 3 OF 5

REVISIONS			
REV.	DESCRIPTION	DATE	APPROVED

10Ga Mesh Wire  
Qty - 48

7Ga Cross Wire  
Qty 3

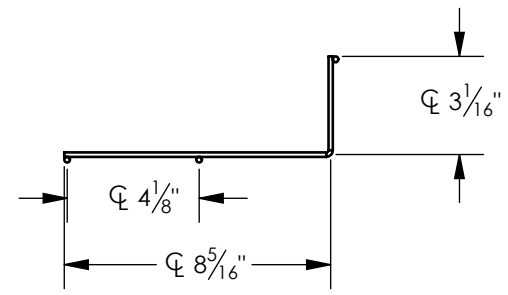
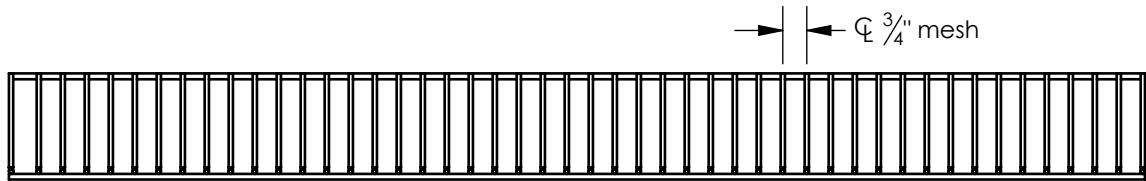
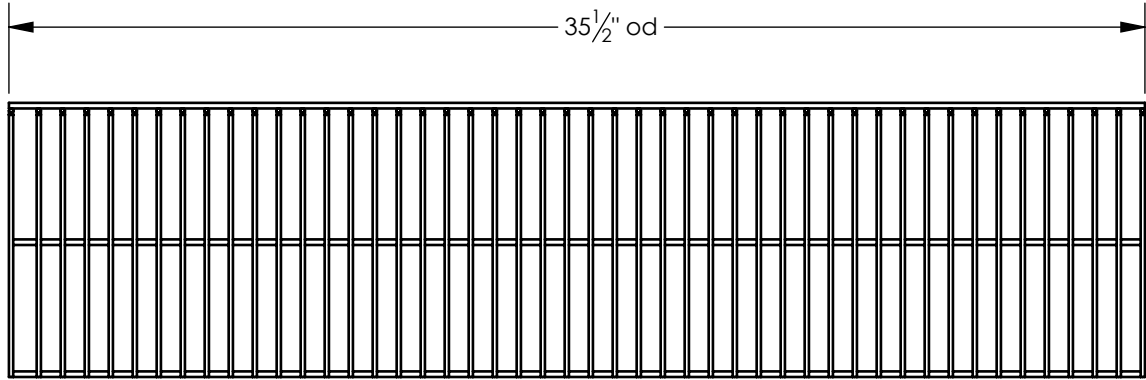
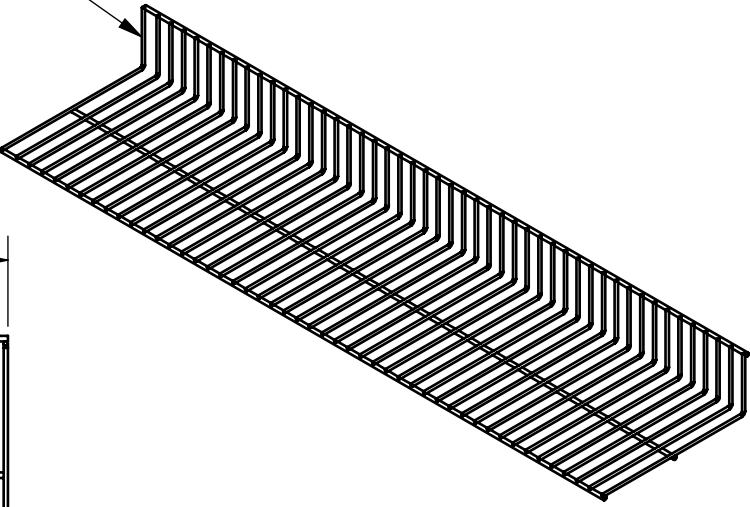

NOTES:

1. MATERIAL: 10GA MESH, 1GA CROSS
2. BLANK SIZE:
3. PROGRAM:
4. BEND RADIUS:
5. BEND DEDUCTION:
6. DEBURR ALL SHARP EDGES AND NIBBLE MARKS.
7. FINISH:

UNLESS OTHERWISE SPECIFIED  
DIMENSIONS ARE IN INCHES  
TOLERANCES ARE:  
FRACTIONS DECIMALS ANGLES  
+/- 1/32" +/- .01 +/- 1°  
CUSTOMER

APPROVALS	DATE
Engineered NRD	6-16-14
Drawn NRD	6-16-14
Checked	

**CDW** CREATIVE DISPLAY WORKS INC.

TIER 2

SIZE A DWG. NO. CDW-PASTRY-RISER-2T-T2-ASM REV. A

DO NOT SCALE DRAWING SHEET 4 OF 5

CIRCLE-K

2 PER ASSEMBLY

REVISIONS			
REV.	DESCRIPTION	DATE	APPROVED

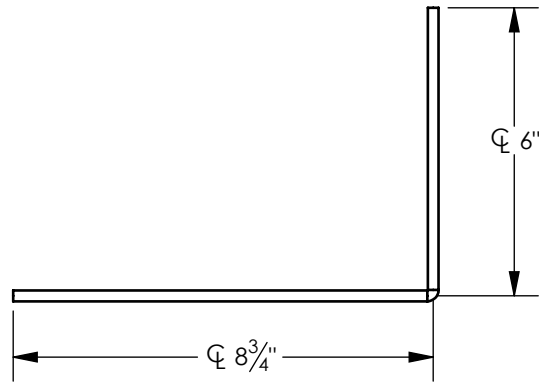
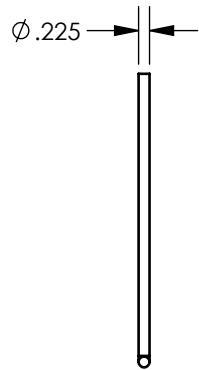
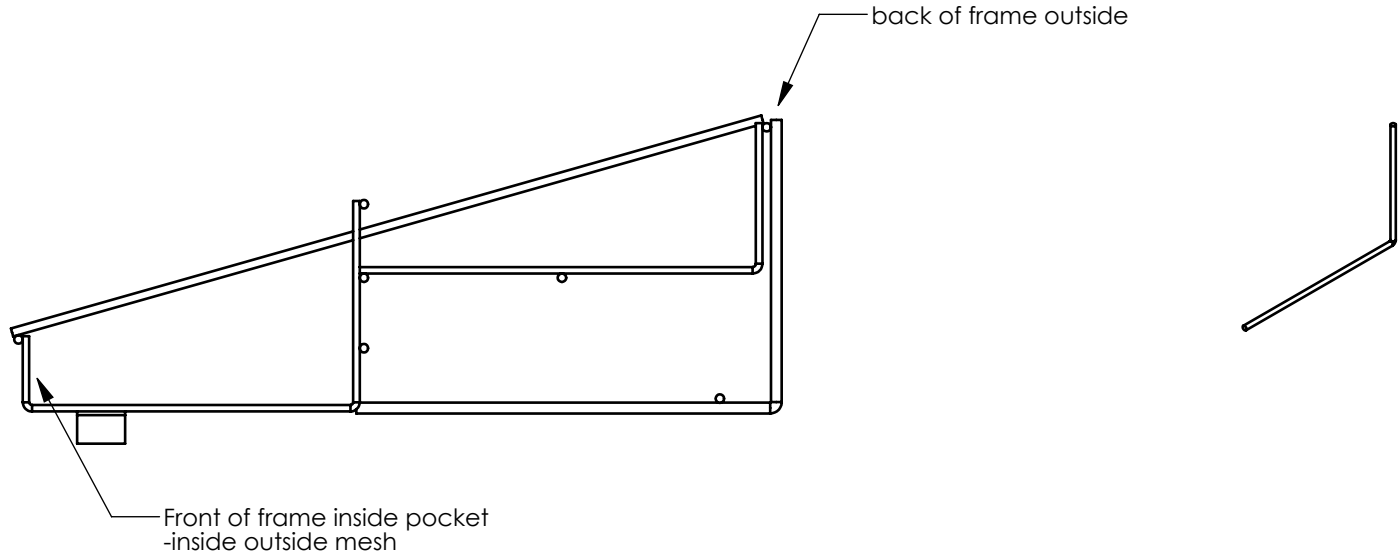

NOTES:

1. MATERIAL: 4GA WIRE
2. BLANK SIZE:
3. PROGRAM:
4. BEND RADIUS:
5. BEND DEDUCTION:
6. DEBURR ALL SHARP EDGES AND NIBBLE MARKS.
7. FINISH:

UNLESS OTHERWISE SPECIFIED  
DIMENSIONS ARE IN INCHES  
TOLERANCES ARE:  
FRACTIONS DECIMALS ANGLES  
+/- 1/32" +/- .01 +/- 1°

APPROVALS	DATE
Engineered NRD	
Drawn NRD	
Checked	

<b>CDW</b> CREATIVE DISPLAY WORKS INC.	
FRAME	
SIZE A	DWG. NO.
DO NOT SCALE DRAWING	
SHEET 5 OF 5	